

# International Conference on Space Optics—ICSO 2004

Toulouse, France

30 March–2 April 2004

*Edited by Josiane Costeraste and Errico Armandillo*



## *Concept & design of the backscatter Lidar for EarthCARE*

*L. Le Hors, C. Wührer, A. Hélière*



International Conference on Space Optics — ICSO 2004, edited by Errico Armandillo,  
Josiane Costeraste, Proc. of SPIE Vol. 10568, 1056830 · © 2004 ESA and CNES  
CCC code: 0277-786X/17/\$18 · doi: 10.1117/12.2552126

## CONCEPT & DESIGN OF THE BACKSCATTER LIDAR FOR EARTHCARE

Lénaïc Le Hors<sup>(1)</sup>, Christian Wührer<sup>(2)</sup>, Arnaud Hélière<sup>(3)</sup>

<sup>(1)</sup> EADS Astrium, 31 avenue des cosmonautes  
31402 Toulouse Cedex 4, France

E-mail : [lenaic.lehors@astrium.eads.net](mailto:lenaic.lehors@astrium.eads.net)

<sup>(2)</sup> EADS Astrium, Ludwig-Bölkow-Allee (Gate 2)  
85521 Ottobrunn, Germany

E-mail : [christian.wuehrer@astrium.eads.net](mailto:christian.wuehrer@astrium.eads.net)

<sup>(3)</sup> ESA-ESTEC, P.O. Box 299  
2200 AG Noordwijk, The Netherland

E-mail : [arnaud.heliere@esa.int](mailto:arnaud.heliere@esa.int)

### ABSTRACT

EarthCARE is one of the three candidate Earth Explorer Core Missions of the ESA Living Planet Programme. It will address the interaction and impact of clouds and aerosols on the Earth's radiative budget. ATLID (ATmospheric LIDar), one of the four instruments of EarthCARE, shall determine vertical profiles of clouds and aerosols physical parameters (altitude, optical depth, backscatter ratio and depolarisation ratio) in synergy with other instruments.

Operating in the UV range at 355 nm, ATLID provides atmospheric echoes with a vertical resolution of 100 m from ground to an altitude of 30 km. Thanks to a high spectral resolution filtering, the lidar is able to separate the relative contribution of aerosol (Mie) and molecular (Rayleigh) scattering, which gives access to aerosol optical depth.

The following addresses the current instrument design as worked-out by Astrium during the EarthCARE Phase-A Study, which was run in 2002-2003 under ESA contract. Besides the basic architecture trade-offs, the emphasis is put on some major technical and technological choices that were done to optimise the lidar performances and efficiency.

### 1. INTRODUCTION

ATLID is a backscatter lidar operating in the UV range operating in synergy with 3 other instruments on the EarthCARE satellite (the Cloud Profiling Radar, the MultiSpectral Imager and the BroadBand Radiometer). It shall determine vertical profiles of clouds and aerosols physical parameters (altitude, optical depth, backscatter ratio and depolarisation ratio) in order to address the interaction and impact of clouds and aerosols on the Earth's radiative budget.

ATLID will sound the atmosphere near the nadir direction (2° offset along-track to avoid over-exposure due to specular reflexion from cirrus clouds) from its sun-synchronous orbit at about 450 km altitude. The retained operation wavelength is 355 nm, where molecular scattering is sufficiently high and detector's response is still good. Three detection channels and an elaborated optical scheme will allow to measure both co- and cross-polarised echoes and separate aerosol (Mie) and molecular (Rayleigh) scattering contributions in the 0 to 30 km altitude range. The instrument will emit short laser pulses with a high repetition rate (100 Hz) along track, so that the data from subsequent shots can be locally averaged for improving signal-to-noise ratio.

### 2. INSTRUMENT ARCHITECTURE

#### 2.1 Instrument major functions

The essential functions of ATLID, summarised in figure 1, can be split into :

- The **Transmitter** : it includes the laser head itself, some of the beam shaping optics and the laser electronics. The laser is a pulsed single-mode Nd:Yag laser which frequency is tripled to the wavelength 355 nm by means of a higher harmonic generator.

- The **Telescope** : usually used to collect the backscattered light, it is here also used in the transmit path (monostatic architecture).

- The **Receiver assembly** : this comprises the transmit / receive diplexer and focal plane optics, including a coarse spectral filtering stage and a High Spectral Resolution (HSR) filter that separates Mie and Rayleigh scattering contributions. It also includes all the detection functions that range from the detector to the analog-to-digital convertor. It comprises three Detection Front-end Units (DFU) located in the

vicinity of the focal plane optics, and one Detection Electronics Unit (DEU).

- The **ATLID Control and Data Management (ACDM) unit** : it ensures the following electrical functions : synchronisation between laser emission and data acquisition ; data processing and data stretching towards the spacecraft ; mechanism drive for redundancy ; thermal regulation functions ; TM/TC and commandability / observability management ; instrument mode management.

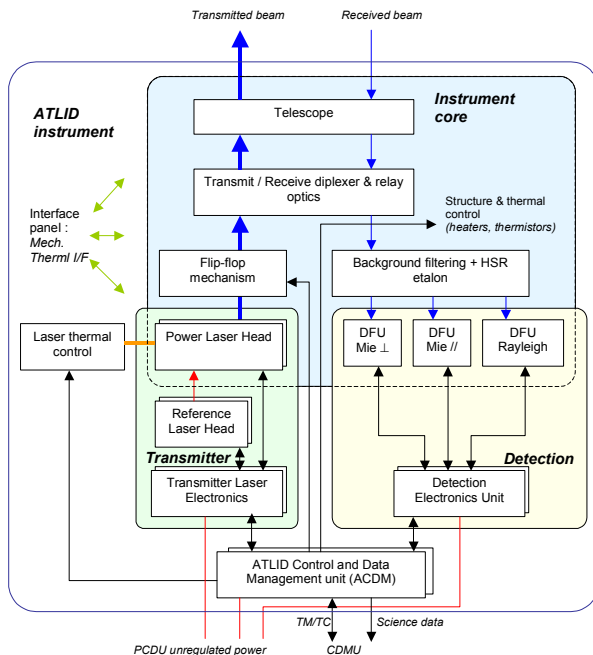

Fig. 1. ATLID functional diagram

## 2.2 ATLID configuration

ATLID instrument is mounted on the EarthCARE platform, inside a dedicated structure that supports another payload (Cloud Profiling Radar). An interface base-plate allows the accommodation of the whole instrument as a self-contained package, and offers a single interface to the platform including all functions associated (mechanical, thermal, electronics). An overview of the instrument is presented on figures 2 and 3.

The instrument core includes the emit/receive telescope, the telescope base-plate, on which are mounted the optical bench assembly and the nominal and redundant Power Laser Heads (PLH). The opto-mechanical architecture is based upon a mono-static concept: the transmit and receive beams propagate through the same telescope. This architecture allows to relax the telescope and optics stability requirements without use of a Rx/Tx co-alignment mechanism, and to minimize the receiver field-of-view diameter, hence improving the daytime performance.

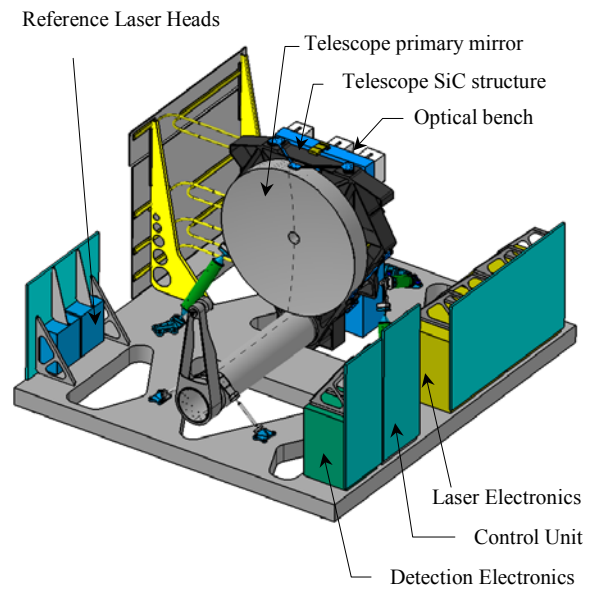

Fig. 2. ATLID configuration (front view)

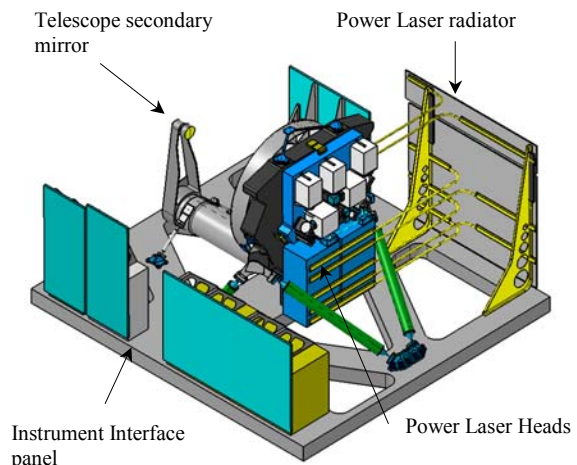

Fig. 3. ATLID configuration (back view)

The telescope is an afocal Cassegrain with 600 mm entrance diameter and 20 mm output beam diameter. The focus quality is thermally adjusted by means of controlled heaters, avoiding the need for a refocusing mechanism.

The transmitter is based on a Power Laser Head (PLH), seeded by a Reference Laser Head (RLH). A beam expander is utilised to match the optical bench assembly beam diameter. The laser beam divergence is adjusted at this expander level in order to fit the eye safety requirement. The PLH, emitting in UV (355 nm), is cooled by means of a dedicated radiator mounted on the anti-sun side. Two sets of laser heads are implemented on the base-plate (cold redundancy), the switching being performed by a flip-flop mechanism.

The optical bench features a transmit / receive switch based on a passive diplexer, using a polarising beam splitter. The transmit / receive optics comprises a field stop, a coarse background etalon and an interference filter for the Earth background rejection. The Mie/Rayleigh backscattering separation is based on a High Spectral Resolution filter (Fabry-Perot etalon).

Three identical detection front-end units are used for three channels (Mie co-polarised, Rayleigh and Mie cross-polarised channels), including optics, detector and proximity electronics. The detector is a Low Light Level CCD (L3CCD) optimised for UV sensitivity. The internal amplification inside the read-out register together with the L3CCD die cooling allows the noise per shot to be dramatically reduced, hence allowing quasi photon-counting.

The remote electronics are the Detection Electronic Units (DEU), the Transmitter Laser Electronics (TLE) and the ATLID Control and Data Management (ACDM) units. The redundancy scheme includes a full cold redundancy for the remote electronic functions, with box-redundancy for the TLE and internal redundancy for the DEU and ACDM. All these dissipative electrical units are implemented at the periphery of the interface panel and support their own radiators, radiating through the apertures of the CPR support structure. The DEU operates the Detector Front-ends and provides timing sequence (main clocks) and secondary power. It provides the science data to the ACDM. The TLE operates the laser heads and provides power supplies and control functions. The ACDM operates the DEU and TLE and provides control (synchronisation) of all equipments, power and data buses to these units and interface with the platform.

### 3. MECHANICAL DESIGN

The proposed mechanical design of the instrument consists in two separate areas:

- The **high stability area**: This assembly includes all the devices involved in the opto-mechanical stability namely, the telescope, the optical bench and the power laser head. By gathering them in an assembly where direct interfaces are managed (i.e. optical bench and PLH directly supported by the telescope), and where this assembly is mechanically de-coupled from the rest of the instrument, the design is clearly oriented in order to provide the best stability performances.

- The **low stability area**: These assemblies do not enter directly in the instrument stability budget. They consist of the interface plate and all associated electronics' (DEU, ACDM, TLE's, RLH's), and of the thermal and secondary structures. Therefore their mechanical support can be managed basically compared to the telescope assembly.

An all Silicon-Carbide (SiC) telescope design has been retained for instrument core. This technology was developed and validated in the past years at Astrium and is now baselined for almost all future instruments in the company. It offers high stiffness/mass ratio and highly stable thermo-elastic stability thanks to the low CTE ( $2 \cdot 10^{-6}$ ) and high thermal conductivity of the material.

The mechanical mounting of the primary mirror, optical bench, and laser heads onto the telescope structure is a key point for optical performances: iso-static mounts are implemented at these interfaces, which allow to achieve an accurate alignment with low induced stresses (and therefore low distortions in the opto-mechanical assembly).

The mounting of the telescope on the interface plate is the main link between the 'low' and 'high' stability areas. This interface is achieved via a set of four CFRP struts at the aft part of the telescope, plus two small invar struts below the secondary mirror support. These struts provide an iso-static link to the interface plate.

The overall mechanical design of the Atlid telescope and of its iso-static interfaces has been fully validated by Astrium in 2002 on a quite similar telescope named "RSI", which was developed for an export programme. The figure 4 below shows the similarity of the two telescopes, which are both all-SiC with a 600 mm diameter primary mirror.

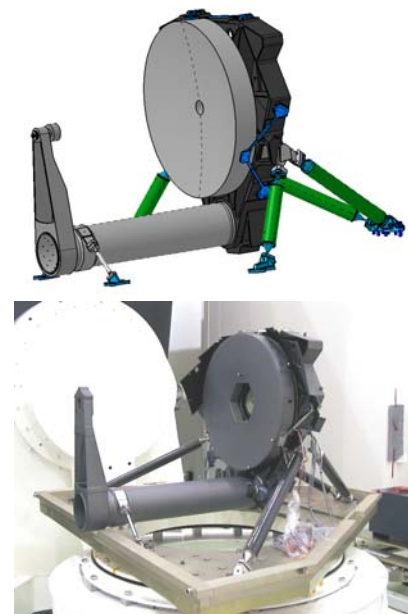

Fig. 4. *Top* :The Atlid telescope design .  
*Bottom*: the Astrium all-SiC telescope for the "RSI" export programme.

#### 4. TRANSMITTER DESIGN

ATLID transmitter consists of :

- A **Reference Laser Head (RLH)** : it provides to the power laser head a frequency stabilized continuous wave output signal of about 20 mW at about 1064 nm. Its frequency is stepwise tunable to allow frequency scan operations for calibration purposes.
- A **Power Laser Head (PLH)**: it includes (figure 5) a local power oscillator, a power amplifier stage and a higher harmonics generator. It is seeded by the RLH and provides short energetic pulses at 355 nm with a repetition frequency of 100 Hz.
- The **Transmitter Laser Electronics (TLE)** forming the interface to the Atlid instrument and including all electronics for operating the RLH and PLH modules.

All these units will be made cold redundant without cross-strapping. The RLH and PLH boxes are thermally completely isolated. All power loss are dissipated via dedicated thermal interfaces to a set of heatpipes and the deep space looking instrument radiator.

The RLH is a direct reuse of the reference laser of the ALADIN instrument transmitter, currently under development for AEOLUS mission (ESA Earth Explorer). It is designed as a dedicated unit containing two separate laser-diode-pumped non-planar Nd:YAG ring lasers, the Reference Laser (RL) and the Seed Laser (SL). The RL is stabilised to an external reference and provides a highly stable optical frequency, which is used as reference for transmitter operation over lifetime. The SL is built up identically but is linked to the RL by a fast broadband frequency locked loop. This allows to reproducibly tune the SL frequency relative to RL.

The SL output signal is fed via an optical fibre into the Power Laser Head (PLH). It seeds the cavity of the local power oscillator, where the signal is amplified and converted to a continuous pulse sequence by means of Q-switching. The length of the cavity is adapted to the frequency of the seed signal by a special control loop. The resulting pulses with a width of <15ns and a repetition rate of about 100 Hz are fed into the subsequent power amplifier stage. Longitudinal pumping has been retained for both local power oscillator and power amplifier stage, in order to get maximum efficiency for the transmitter and smaller interface budgets (mass, volume and power).

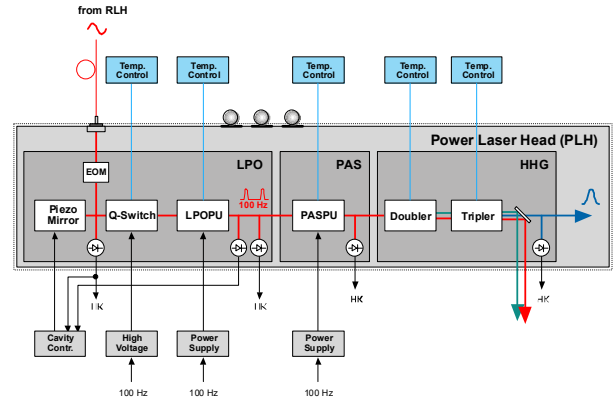

Fig. 5. Power laser head block diagram

In the higher harmonics generation stage, the frequency of the power amplifier stage output signal is doubled to 532 nm and subsequently tripled to 355 nm by superposing the red and the green signals. All three beams are emitted outside the PLH box, the UV beam is adjustable by means of a dedicated alignment device. The UV pulses have an energy higher than 19 mJ, a spectral line-width smaller than 50 MHz and a frequency stability better than 30 MHz over one month.

#### 5. RECEIVER DESIGN AND PERFORMANCES

##### 5.1 Optical functions

ATLID optical block diagram is presented on figure 6.

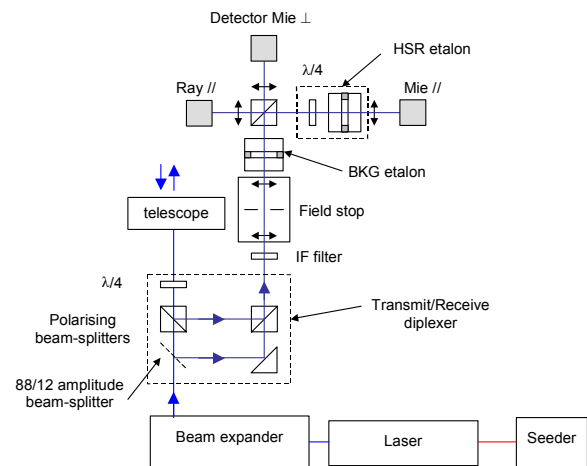

Fig. 6. ATLID optical block diagram

The major functions of optical bench are :

- **Transmit / receive diplexing** : the Tx/Rx diplexer transmits most of laser energy to the telescope and sends the co-polarised backscatter signal and most of cross-polarised backscatter signal to the receive path. It

is based on polarising and amplitude beam-splitters and a quarter-wave plate:

- The laser beam comes on diplexer with linear polarisation. 88% of laser energy is transmitted by the 88/12 beam-splitter and then transmitted by a polarising beam-splitter cube. The beam polarisation is then transformed by the quarter-wave plate into a circular polarisation ; laser beam is finally sent to the telescope by a periscope mirror

- The backscattered signal incident beam has circular polarisation. Its polarisation is transformed into linear polarisation by the quarter-wave plate. Then, co-polarised signal is successively reflected on two polarising beam-splitter cubes and sent to receiver path. Cross-polarised signal is transmitted by the first polariser, part of the energy (12%) is reflected on amplitude beam-splitter, and transmitted by the second polariser to the receiver path

- **Coarse filtering** : most of background light (wide spectrum radiance from Earth) is rejected by a coarse filtering stage consisting of one narrowband interference filter (FWHM = 1 nm around laser wavelength 355 nm) and one coarse Fabry-Perot etalon, called background etalon (FWHM = 77 pm)

Spatial filtering : the light collected by the telescope is filtered through a field stop ; its role is to limit receiver field-of-view around laser footprint image in order to reject background light coming out of useful field-of-view

- **Rayleigh / Mie separation** : the Mie/Rayleigh separation is performed with a High Spectral Resolution Fabry-Perot etalon, called HSR etalon. The linearly polarised beam is made circular by means of a quarter-wave plate. Most of Mie backscatter spectrum (narrow spectrum around central wavelength) is transmitted by the HSR etalon and focused on dedicated detector. Most of Rayleigh backscatter (wide spectrum around central wavelength) is reflected by HSR etalon and crosses a second time the quarter-wave plate ; as a result, its polarisation direction has been rotated (90°) and it crosses the polariser before being focused on Rayleigh channel detector. The cross-polarised beam is directly transmitted by the polariser to the dedicated detector (cross-polarised channel)

- **Signal detection** : after filtering, the beam are focused on the 3 detectors. For each channel, the CCD detector and its proximity electronics are located in an assembly called Detection Front-end Unit (DFU).

## 5.2 Optical bench accommodation

Optical bench accommodation is presented on figure 7. Optics and detectors are mounted on a Aluminium honeycomb / CFRP sandwich (60 mm thick) which allow to manage a good stiffness as well as a flexibility in the units and interfaces location.

The beam diameter before field-stop is 20 mm ; after field-stop, it is increased to 30 mm to minimise angles on Fabry-Perot etalons.

The combination of a thermal housing and decoupling isostatic mounts performs thermal isolation. The power dissipated by the detection front-end units is evacuated by means of heatpipes coupled to a dedicated radiator on the anti-sun side of the satellite.

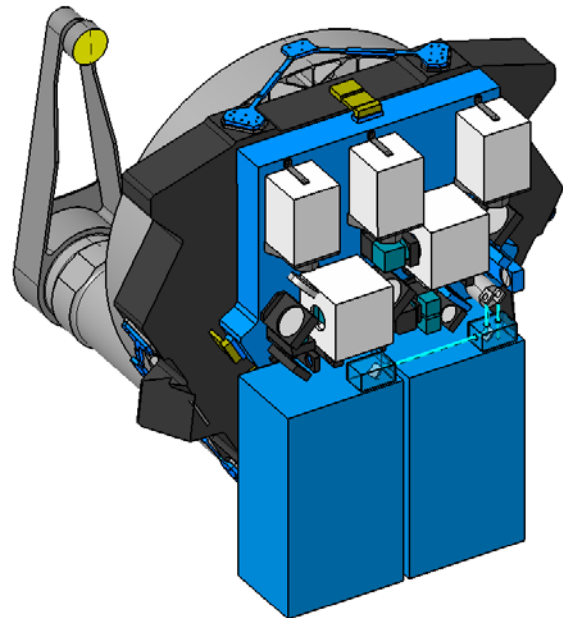

Fig. 7. ATLID optical bench

## 5.3 High Spectral Resolution filtering stage principle and design

The separation of Mie (aerosol) and Rayleigh (molecular) scattering contributions in the UV range requires the use of a High Spectral Resolution (HSR) Fabry-Perot etalon. Whereas molecular scattering induces a broadening of laser pulse spectrum to a width of some 3 GHz, the scattering by aerosols maintains a very narrow spectrum (~50 MHz) around laser central wavelength. The HSR filtering around laser central wavelength thus allows to transmit most of Mie scattered light while reflecting most of Rayleigh scattered light, as depicted in figures 8 & 9 below.

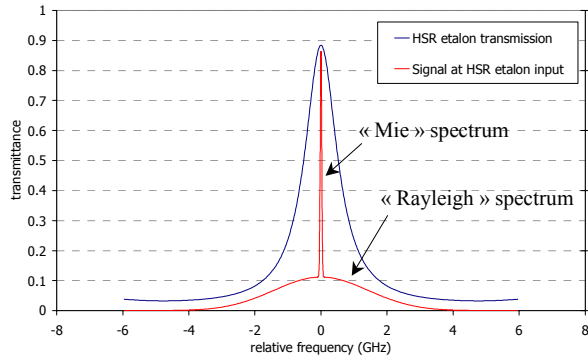

Fig. 8. Light spectrum at HSR filter input and HSR filter spectral transmittance

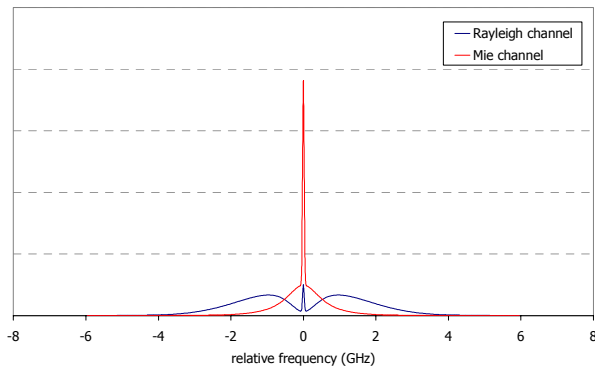

Fig. 9. Light spectrum transmitted and reflected by HSR filter

A sequence of transmissions and reflections on polarising components as described on figure 10 allows to route the Mie scattering contribution to the “Mie” channel while sending the Rayleigh scattering contribution to the “Rayleigh” channel. The incident beam is s-polarised and reflected by a polarising beam-splitter. The polarisation becomes circular after crossing a quarter-wave plate. The HSR filter transmit a narrow spectral bandwidth around central wavelength to the Mie channel. The light reflected by the HSR filter crosses again the quarter-wave plate. As a result, its polarisation direction is rotated by 90°, and the beam is then transmitted by the polarising beam-splitter to the Rayleigh channel.

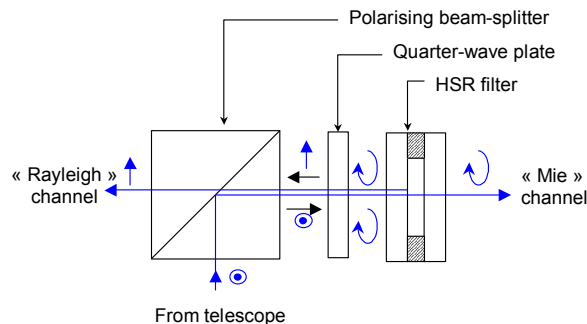

Fig. 10. HSR filter principle

The same concept has been retained for both coarse background etalon and HSR etalon. Since high mechanical stability and low thermal sensitivity are required, it is proposed to use optical contacting technology, which was retained and qualified in the frame of ALADIN instrument development.

The current design is shown in figure 11. It is based on the optical contacting of two reflective silica plates on a 16 mm-thick zerodur glass spacer. Thanks to the very low expansion of zerodur, high cavity length stability is achieved. The thermal sensitivity is  $\delta\lambda/\Delta T=0.025$  pm/K. The etalon temperature stability requirement is then 0.32 K rms in the short term and  $\pm 0.55$  K in the long term to keep perfect tuning to the laser frequency. No absolute tuning is required, which relaxes manufacturing requirements. The etalon is thermally stabilised by fine thermal control and monthly calibration sequences allow tuning the laser to the etalon peak transmission frequency.

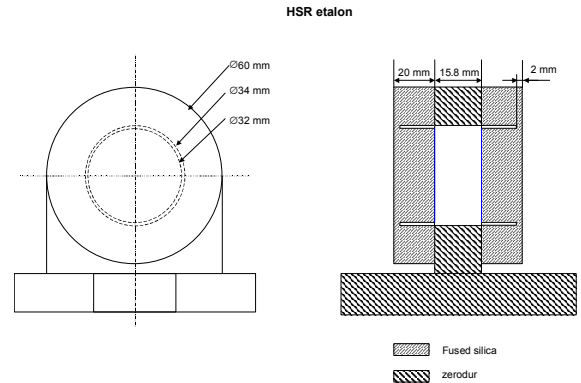

Fig. 11. HSR etalon design

## 6. ATLID PERFORMANCE

ATLID instrument will be able to measure Mie and Rayleigh scattering contributions between altitudes – 0.5 and 30 km. The radiometric performance is expressed in terms of accuracy in Mie and Rayleigh signal retrieval accuracy at instrument input.

The reference target is an unpolarised subvisible cirrus cloud between altitudes 9 and 10 km, with a backscatter coefficient of  $8.10^{-7} \text{ m}^{-1}.\text{sr}^{-1}$  and an extinction coefficient of  $4.10^{-5} \text{ m}^{-1}.\text{sr}^{-1}$ , whose profile is measured in daytime conditions, with a dense cloud deck at an altitude of 4 km.

In the previous conditions, and at the maximum altitude of the orbit (483 km), the absolute accuracy of the derived input signal is 37% for the Mie scattering signal (with 100 m vertical integration length) and 14% for the Rayleigh scattering signal.

The instrument is also able to measure the depolarised backscatter signal of a subvisible cirrus in the same

background conditions : when the cirrus backscatter coefficient is  $2.6 \times 10^{-5} \text{ m}^{-1} \cdot \text{sr}^{-1}$  and its depolarisation ratio is 10%, the absolute accuracy of the derived input signal is 46% for the Mie scattering signal.

## 7. INSTRUMENT INTERFACE BUDGETS

The main instrument mission and sizing parameters and interface budgets are summarised in the following table.

Table 1. Summary of instrument main parameters

<b>Mission parameters</b>	
Orbit type	Sun-synchronous, LTDN 10:30
Mean orbit altitude	450 km
Pointing	2° offset nadir along track
Vertical sampling	100 m between altitudes – 0.5 and 20 km 500 m between altitudes 20 and 30 km
Wavelength	355 nm
<b>Instrument main sizing parameters</b>	
Telescope primary mirror diameter	600 mm
Laser pulse energy	19 mJ at 355 mJ
Pulse repetition frequency	100 Hz
Receiver field-of-view	25 μrad
HSR filter FWHM	0.5 pm
<b>Instrument interface budgets</b>	
Mass	230 kg
Typical power consumption	310 W
Scientific datarate	822 kb/s
Envelope	1600×1480×930 mm

## 8. CONCLUSION

ATLID, the EarthCARE backscatter lidar, is considered as a key instrument for atmospheric research in the frame of ESA Earth Explorer Missions. A new design has been worked-out by EADS Astrium, that combines high heritage from other instruments like AEOLUS-ALADIN and RSI and new technologies like L3CCD detectors. A new laser design, based on longitudinal pumping, allows to propose a compact instrument configuration with simple decoupled interfaces to the spacecraft.

## 9. ACKNOWLEDGEMENT

This work was funded by the European Space Agency In the frame of the EarthCARE Phase A study contract.

EADS Astrium was prime contractor for the definition of ATLID instrument, with contribution from the following European companies : Saab Ericsson Space (Sweden, for instrument electronics) and TNO-TPD (The Netherlands, for optics detailed definition).

## 10. REFERENCE

[1] EarthCARE – Earth Clouds, Aerosols and Radiation Explorer, *report for assessment, ESA SP-1257(1), September 2001*